



S-CUBE P KAT EC

**Cassoni centrifughi pale rovesce
per aria ad alta temperatura**

Backward curve centrifugal box fans

for high temperature air of industrial kitchens (180°C)



Basso consumo energetico grazie alla **tecnologia EC**
Low energy consumption thanks to **EC Brushes**

S-CUBE P KAT EC aspiratori cassonati | box fans

DESCRIZIONE

I cassoni a pale rovesce insonorizzati S-CUBE P KAT EC sono progettati per l'aspirazione su cappe da cucina impiegate nel campo della ristorazione e in impianti industriali. La caratteristica peculiare di questo cassone consiste nell'avere il motore separato dal flusso d'aria per mezzo di un setto in lamiera zincata, preservando così il motore dalle tipiche sostanze di natura grassa e residui di combustione prodotti dai fornelli delle cucine e riducendo al minimo necessario le operazioni di pulizia e di manutenzione. I pannelli a doppio strato isolati acusticamente riducono il livello di rumore per un migliore comfort anche in caso di installazioni interne. Sono adatti a convogliare aria in un range di temperatura compreso tra -20°C e +180°C.

COSTRUZIONE

- Telaio realizzato con profili di alluminio e pannelli smontabili a doppio strato imbottiti con materiale fonoassorbente (sp. 25 mm).
- Esecuzione 5 (accoppiamento diretto con girante a sbalzo su motore flangiato B5).
- Isolamento acustico interno ai pannelli in materiale autoestinguente.
- Girante a pale rovesce in acciaio zincato bilanciata dinamicamente secondo UNI ISO 21940-11:2017.
- Piedi di fissaggio con fori predisposti per il sollevamento e una facile installazione.

MOTORE

Motori sincroni a magneti permanenti con driver (inverter) integrato conformi agli standard IEC60034-30-2-2016 che garantiscono una efficienza oltre i valori IE5 e un importante risparmio di energia (>30%) e quindi minori emissioni di CO₂ nell'ambiente. Grado di protezione IP55. Temperatura ambiente -20°C +40°C. Controllo di velocità tramite il collegamento diretto a regolatore 0-10V, MODBUS o inverter.

ACCESSORI

- Tettuccio parapigioggia
- Supporti antivibranti
- Piedi di supporto a pavimento
- Raccordo Quadro-Tondo
- Raccordo aspirante Tondo
- Giunto antivibrante
- Vaschetta raccogli grasso
- Pannello inferiore con scarico
- Regolatore EC.

DESCRIPTION

S-CUBE P KAT EC backward curved impellers box fans are designed for ducted or direct exhaust on kitchen hoods used in the field of catering and industrial plants. The special feature of this box consists in having the motor separated from the air flow by means of a galvanised sheet metal panel, thus preserving the motor from typical oily substances and combustion residues produced by cookers and reducing cleaning and maintenance operations to a minimum.

The double skin acoustically insulated panels reduce the noise level for a better comfort also in case of indoor installations.

Suitable to convey air in a range of temperature from -20°C up to +180°C.

CONSTRUCTION

- Aluminium frame with double skin sound absorbing insulated panels removable from the impeller side (thick 25 mm).
- Motor external to the stream, B5 execution directly coupled to the impeller.
- Sound absorbing and self-extinguishing material between the steel sheet layers of the panels.
- Galvanized steel sheet backward curved impeller dynamically balanced according to UNI ISO 21940-11:2017.
- Punched mounting feet for an easy handling and fixing.

MOTOR

Permanent-magnet synchronous motors with integrated driver (inverter) complying with IEC60034-30-2-2016 standards that ensure efficiency beyond IE5 values and significant energy savings (>30%) and thus lower CO₂ emissions to the environment. IP55 degree of protection. Ambient temperature -20°C +40°C. Speed control by direct connection to 0-10V controller, MODBUS or inverter.

ACCESSORIES

- Water-proof protection cover
- Anti-vibration supports
- Floor support feet
- Square to round outlet adaptor
- Round spigot inlet cone
- Flexible connector
- Grease collector tray
- Lower panel with drain
- EC regulator.

VERSIONI | VERSIONS



S-CUBE P KAT

Versione con motorizzazione AC idonea al trasporto di gas caldi, max. 180°C in continuo
AC motor versions suitable for air temperature up to 180°C in continuous service

PRESTAZIONI | PERFORMANCE

S-CUBE P KAT EC

Le prestazioni aerauliche sono rilevate in conformità alla norma EN ISO 5801/AMCA 210 con densità dell'aria standard avente peso specifico 1,2 Kg/m³. Alimentazione 230V/1Ph/50Hz o 400V/3Ph/50Hz. Air performances measured according to EN ISO 5801 / AMCA 210 standard with air density with 1,2 Kg/m³ specific weight. Power supply 230V/1Ph/50Hz or 400V/3Ph/50Hz.

Lp Livello di pressione sonora rilevato in condizioni di campo libero, propagazione emisferica, categoria di misura C a norma EN ISO 13349, nel punto di massimo rendimento, alla distanza di 3 metri dal lato aspirazione e si presenta solo per fini comparativi. Sound pressure level measured in free field conditions, propagation hemispherical, measurement category C in accordance with EN ISO 13349, at the point of maximum efficiency, at a distance of 3 meters, inlet side (for comparative purposes only).

Lw Livello di potenza sonora ottenuto secondo norma ISO 3746. Tolleranza +/- 3 dB(A). Sound power level obtained in accordance with EN ISO 3746. Tolerance +/- 3 dB(A).

S-CUBE P KAT 350 EC

Code	Tipo Type	Modello Model	U	Pm (kW)	In (A)	IP/CL
1SK3552	S-CUBE P KAT	350 EC	M	0,60	4,00	55/F

LIVELLI SONORI | SOUND LEVELS dB(A)

Hz		63	125	250	500	1000	2000	4000	8000	TOT
350	Lw	38	52	59	62	62	59	56	45	67
	Lp	26	40	47	50	50	47	44	33	55

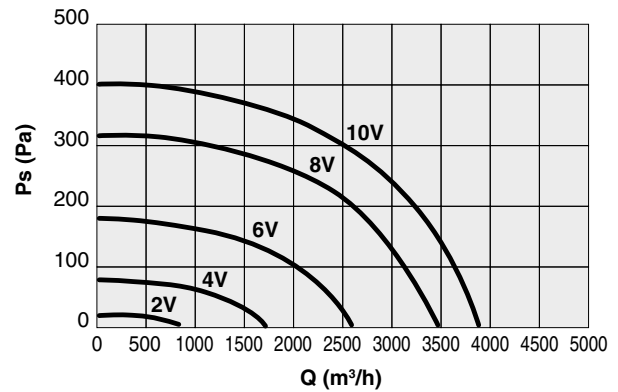

S-CUBE P KAT 400 EC

Code	Tipo Type	Modello Model	U	Pm (kW)	In (A)	IP/CL
1SK4052	S-CUBE P KAT	400 EC	M	1,57	10,60	55/F

LIVELLI SONORI | SOUND LEVELS dB(A)

Hz		63	125	250	500	1000	2000	4000	8000	TOT
400	Lw	41	55	63	66	66	63	58	48	71
	Lp	29	43	51	54	54	51	46	36	59

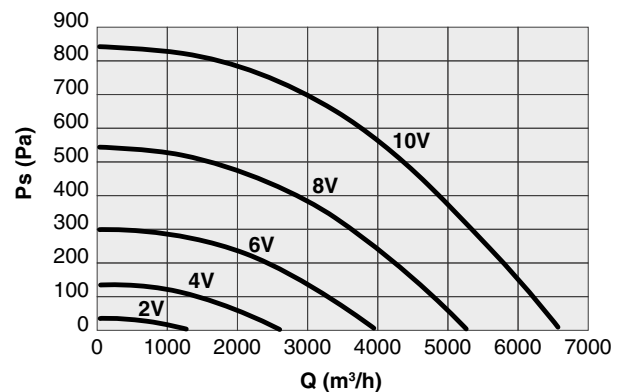

S-CUBE P KAT 450 EC

Code	Tipo Type	Modello Model	U	Pm (kW)	In (A)	IP/CL
1SK4552	S-CUBE P KAT	450 EC	M	1,30	8,80	55/F

LIVELLI SONORI | SOUND LEVELS dB(A)

Hz		63	125	250	500	1000	2000	4000	8000	TOT
450	Lw	41	57	64	68	69	66	61	51	73
	Lp	29	45	52	56	57	54	49	39	61

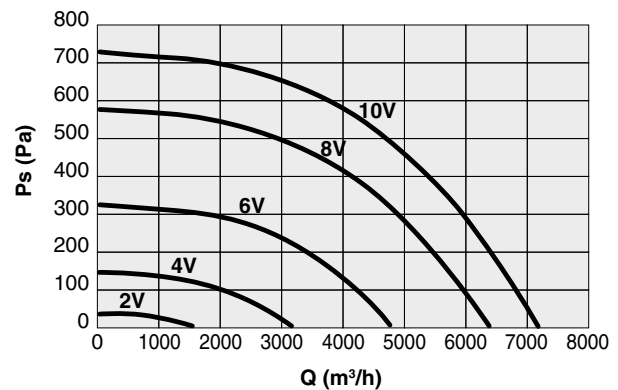

SEZ.
1.11

S-CUBE P KAT EC aspiratori casonati | box fans

S-CUBE P KAT 500 EC

Code	Tipo Type	Modello Model	U	Pm (kW)	In (A)	IP/CL
1SK5052	S-CUBE P KAT	500 EC	T	2,60	4,39	55/F

LIVELLI SONORI | SOUND LEVELS dB(A)

Hz	63	125	250	500	1000	2000	4000	8000	TOT	
500	Lw	46	56	65	68	70	67	60	51	74
	Lp	34	44	53	56	58	55	48	39	62

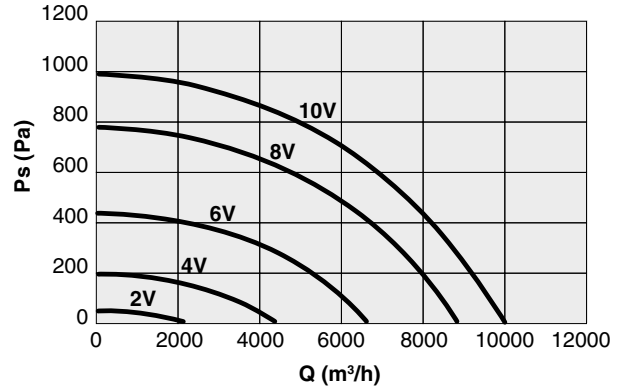

S-CUBE P KAT 560 EC

Code	Tipo Type	Modello Model	U	Pm (kW)	In (A)	IP/CL
1SK5652	S-CUBE P KAT	560 EC	T	3,50	5,90	55/F

LIVELLI SONORI | SOUND LEVELS dB(A)

Hz	63	125	250	500	1000	2000	4000	8000	TOT	
560	Lw	55	66	72	74	76	74	67	58	81
	Lp	43	54	60	62	64	62	55	46	69

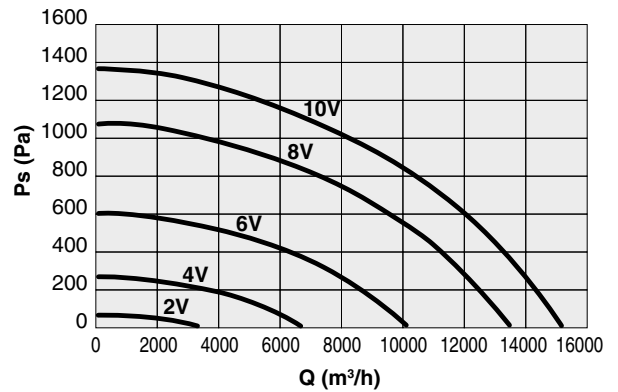

S-CUBE P KAT 630 EC

Code	Tipo Type	Modello Model	U	Pm (kW)	In (A)	IP/CL
1SK6352	S-CUBE P KAT	630 EC	M	1,30	8,80	55/F

LIVELLI SONORI | SOUND LEVELS dB(A)

Hz	63	125	250	500	1000	2000	4000	8000	TOT	
630	Lw	46	58	65	68	69	67	62	54	74
	Lp	34	46	53	56	57	55	50	42	62

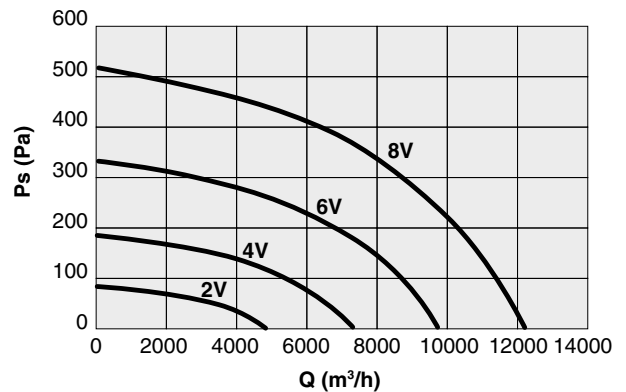

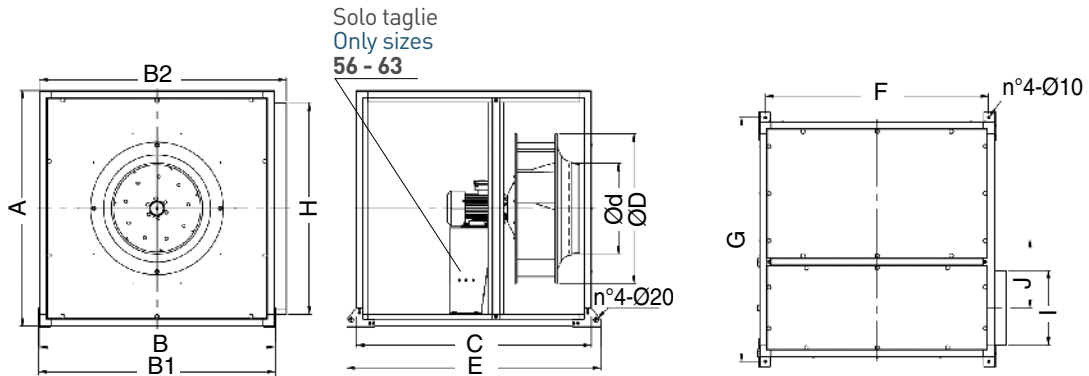

SOLO PER VERSIONE 63 | ONLY FOR VERSION 63

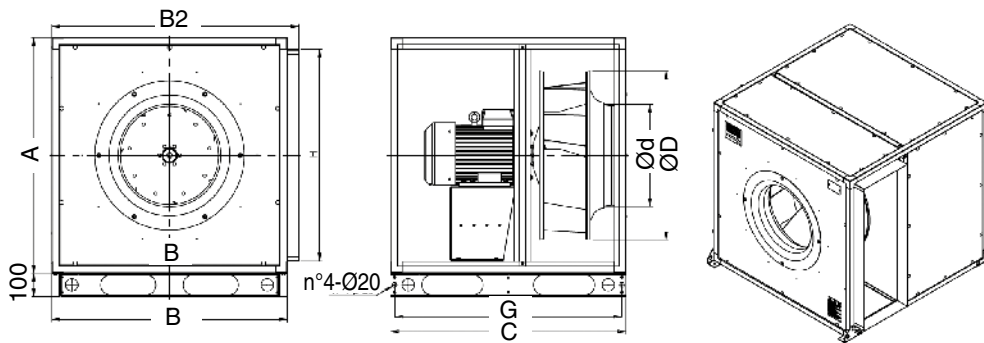

S-CUBE P KAT EC

TIPO TYPE	A	B	B1	B2	C	Ød	ØD	E	F	G	H	I	J	Kg
S-CUBE P KAT 350 EC	650	650	656	689	650	243	404	730	598	686	549	173	188	59
S-CUBE P KAT 400 EC	750	750	756	799	750	275	455	830	698	786	649	208	220	82
S-CUBE P KAT 450 EC	750	750	756	799	750	309	505	830	698	786	649	233	208	85
S-CUBE P KAT 500 EC	750	750	756	799	750	343	566	830	698	786	649	288	180	106
S-CUBE P KAT 560 EC	1000	1000	1006	1050	1000	384	636	1080	948	1036	899	318	290	167
S-CUBE P KAT 630 EC	1000	1000	1000	1050	1000	433	716	1000	-	965	899	353	273	169

Pesi indicativi | Indicative weights

INSTALLAZIONE

Versatilità di posizionamento nella fase di installazione del prodotto, il cassone può essere infatti montato sia in orizzontale che in verticale indifferentemente. Possono inoltre essere installati all'aperto utilizzando l'apposito tettuccio parapiooggia disponibile come accessorio.

INSTALLATION

S-CUBE P KAT EC installation is easy thanks to the highly flexible positioning of the product. Indeed, this box fan can be indifferently installed in both vertical and horizontal position and is suitable for outdoor installations (we suggest the use of a water-proof protection cover, available as accessory).

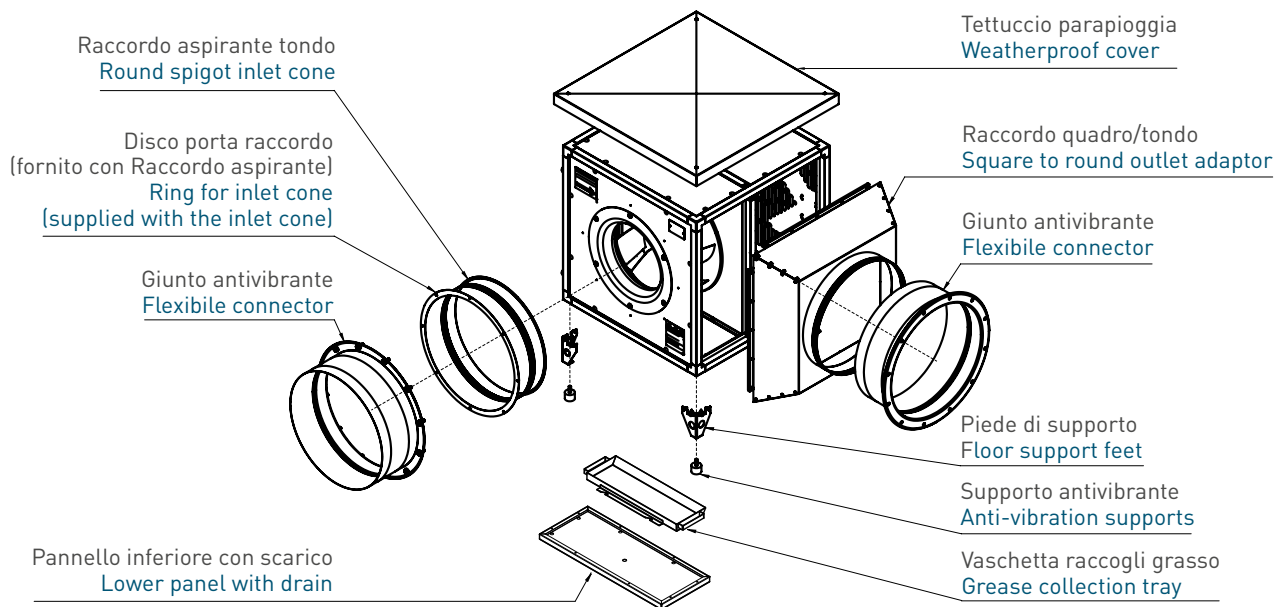

TETTuccio PARAPIOGGIA | WEATHERPROOF COVER

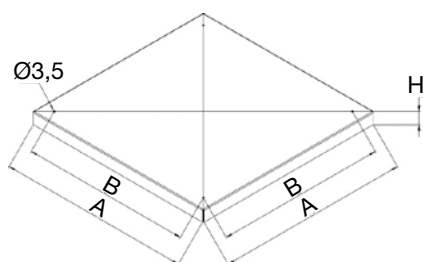

Code	Tipo Type	A	B	H	Kg
5TE0081	35	700	618	35	3,70
5TE0082	40 / 45 / 50	800	720	50	5,00
5TE0083	56 / 63	1050	970	50	8,20

Dimensioni in mm | Dimensions in mm

RACCORDO QUADRO/TONDO | SQUARE TO ROUND OUTLET ADAPTOR

Da abbinare ai piedi 1ST0027.

To be installed with support feet 1ST0027.

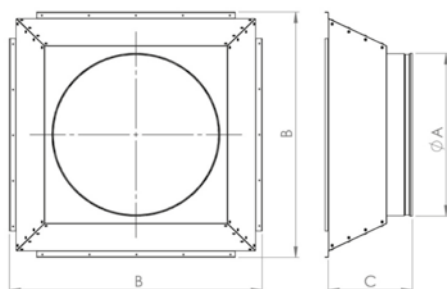

Code	Tipo Type	ØA	B	C	Kg
5RA2026	35	400	655	178	4,4
5RA2014	40	450	753	252	6,4
5RA2015	45	500	753	249	6,2
5RA2018	50	560	753	246	6,3
5RA2019	56	630	1005	246	9,1
5RA2020	63	710	1005	250	9,4

Dimensioni in mm | Dimensions in mm



GIUNTO ANTIVIBRANTE | FLEXIBLE CONNECTOR

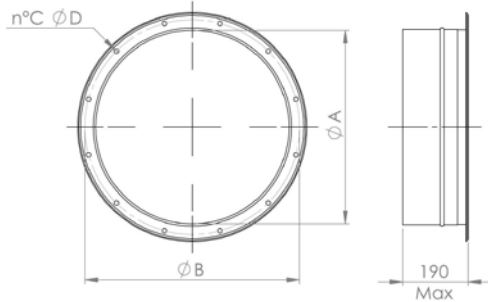

Code	Tipo Type	ØA	ØB	C	ØD	Kg
1SU5101	35	355	395	8	10	1,9
1SU5102	40	405	450	8	12	2,2
1SU5103	45	455	500	8	12	2,4
1SU5104	50	505	560	12	12	2,9
1SU5105	56	565	620	12	12	3,0
1SU5106	63	635	690	12	12	3,4

Dimensioni in mm | Dimensions in mm

RACCORDO ASPIRANTE TONDO | ROUND SPIGOT INLET CONE

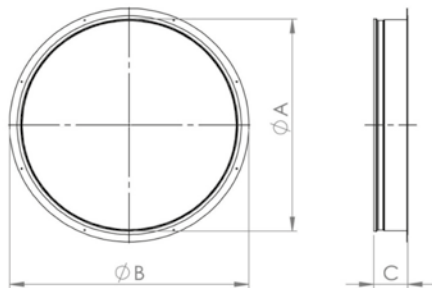

Code	Tipo Type	ØA	ØB	C	Kg
1TR0017	35	400	450	56	0,8
1TR0018	40	450	500	56	0,9
1TR0019	45	500	550	78,5	1,2
1TR0020	50	560	610	78,5	1,3
1TR0021	56	630	680	78,5	1,5
1TR0022	63	710	760	78,5	1,8

Dimensioni in mm | Dimensions in mm

1ST0027 | PIEDE DI SUPPORTO A PAVIMENTO | FLOOR SUPPORT FEET

N°4 piedi da utilizzare in abbinamento al pannello inferiore con scarico condensa e grasso (ad esclusione dei modelli 630).

N° 4 feet to be used coupled with the condensate and grease drain inferior panel (except models 630).

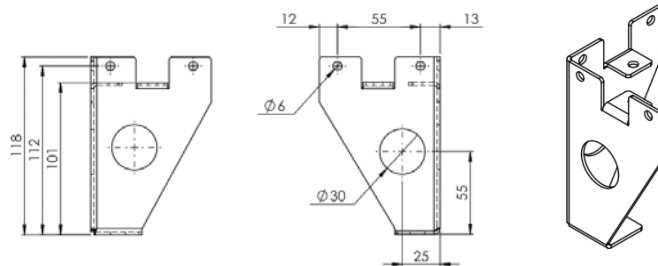

SUPPORTI ANTIVIBRANTI | ANTI-VIBRATION SUPPORTS

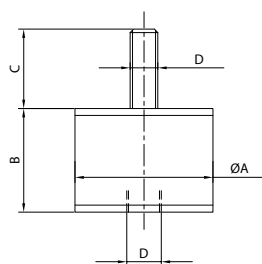

Code	Tipo Type	ØA	B	C	D	Carico a compressione per 1 supporto (Kg) Compression load for 1 support (Kg)
5SU1057	35 / 40	30	20	23	M8	21 ÷ 45
5SU1054	45 / 50 / 56 / 63	40	30	28	M10	46 ÷ 65

Dimensioni in mm | Dimensions in mm



ACCESSORI | ACCESSORIES

VASCHETTA RACCOGLI GRASSO | GREASE COLLECTION TRAY

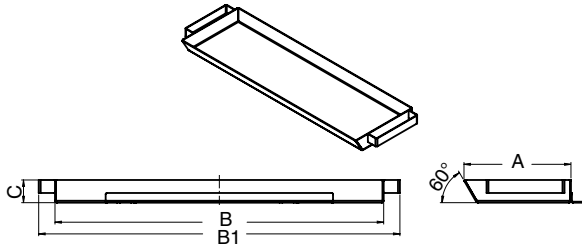

Code	Tipo Type	A	B	B1	C	Kg
1KT0404	35	125	386	436	35	1,1
1KT0405	40 / 45 / 50	165	506	556	35	1,7
1KT0406	56 / 63	230	656	706	35	2,7

Dimensioni in mm | Dimensions in mm

PANNELLO INFERIORE CON SCARICO | LOWER PANEL WITH DRAIN

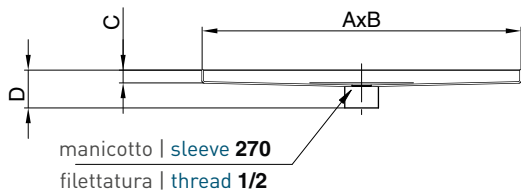

Code	Tipo Type	A	B	C	D	Kg
5PN1586	35	587	212	20	40	1,4
5PN1587	40	687	247	20	40	1,6
5PN1588	45	687	272	20	40	1,7
5PN1589	50	687	327	20	40	2
5PN1590	56	937	357	20	40	2,8
5PN1591	63	937	392	20	40	3

Dimensioni in mm | Dimensions in mm

RV EC | REGOLATORE EC | EC REGULATOR

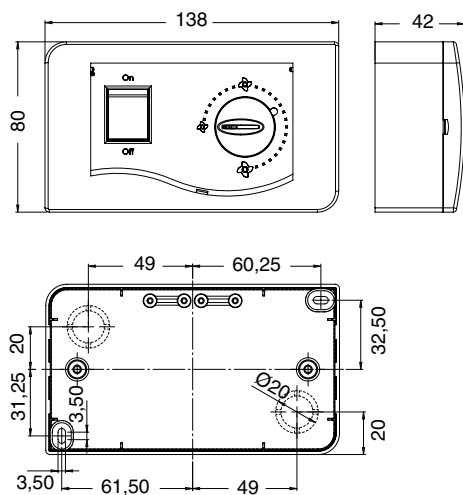

Code	Tipo Type
2RV4197	RV EC 0-10V